

4

3

2

1

REVISION HISTORY			
REV	DESCRIPTION	DATE	APPROVED
PROTO	EC41594	10/17/2011	gjani
REL.	EC43970	3/5/2012	gjani

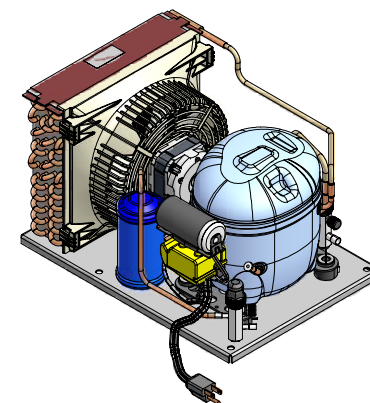
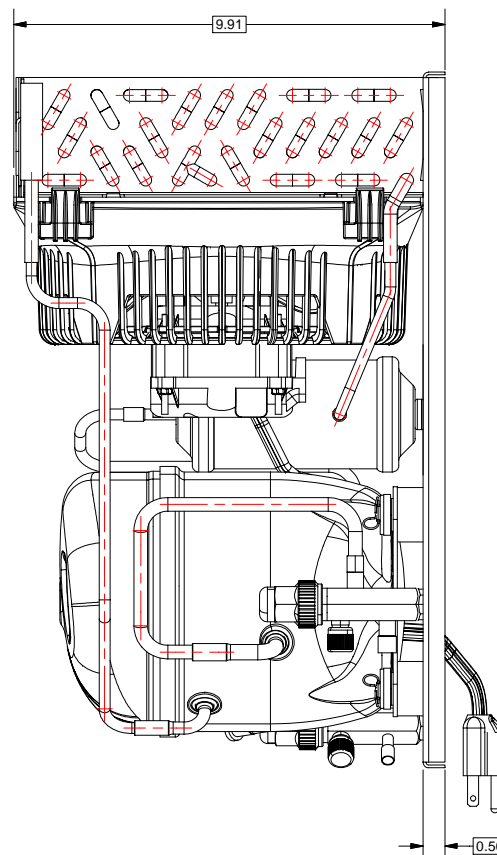
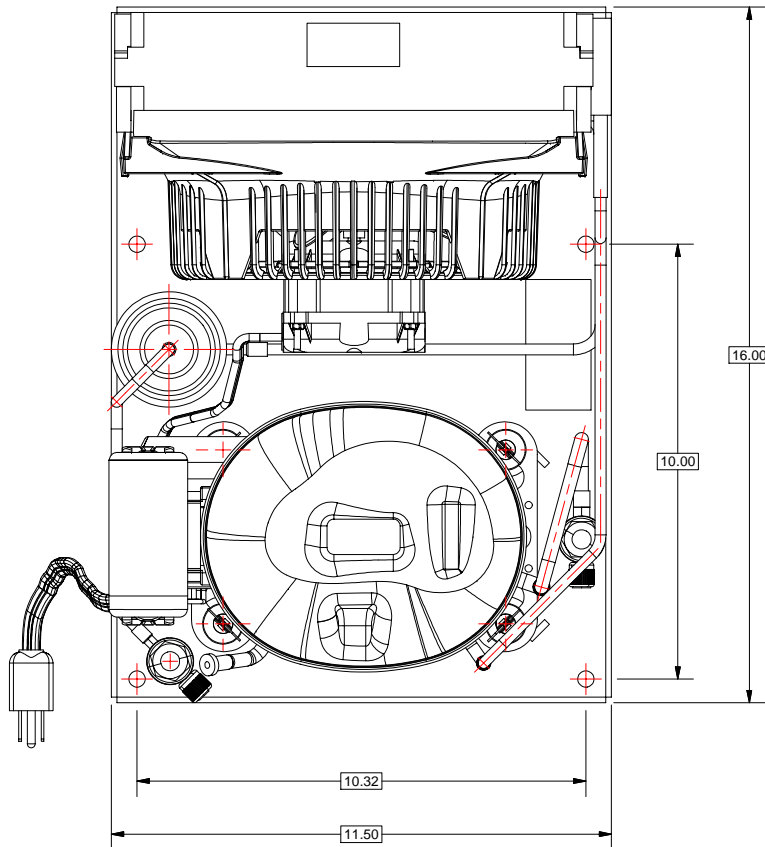

NOTES:

- 1.- COPPER TO COPPER JOINTS USE SILFOS BRAZE. STEEL TO STEEL OR STEEL TO COPPER JOINTS USE SILVER BRAZE
- 2.- ASSEMBLE ELECTRICAL PARTS AS PER DRAWING A
- 3.- FAN CORD EXCESS TO BE FASTENED WITH 70887-1 WIRE TIE

DESCRIPTION		HERMETIC CONDENSING UNIT		
THIRD ANGLE	MATERIAL	DIMENSION	 DWG NO. SU1896-G102	
DESIGN DATE	10/17/2011	DWN.		gjani
LAST REVIEW	3/5/2012	CHK.		gjani
ARCHIVE				

4

3

2

1

4

3

2

1

B

B

A

A

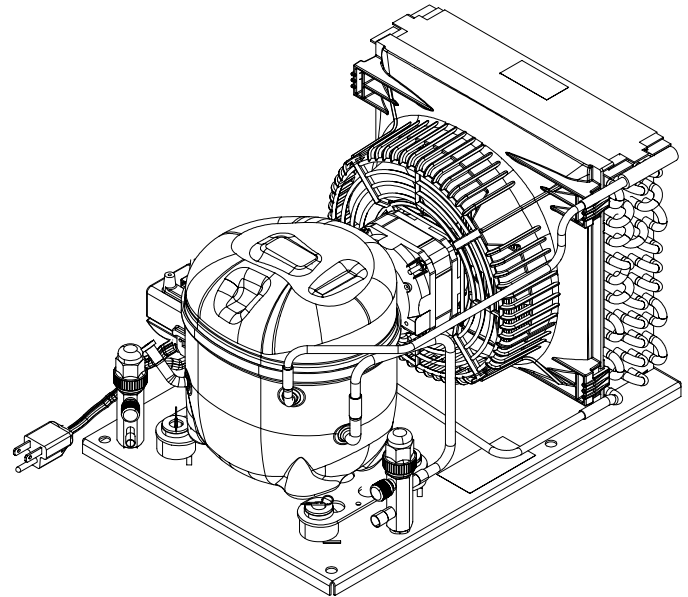
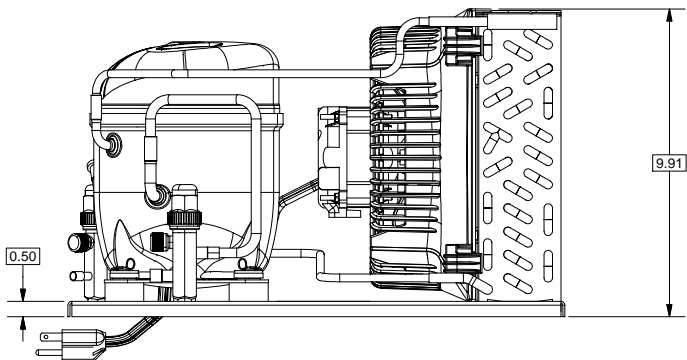
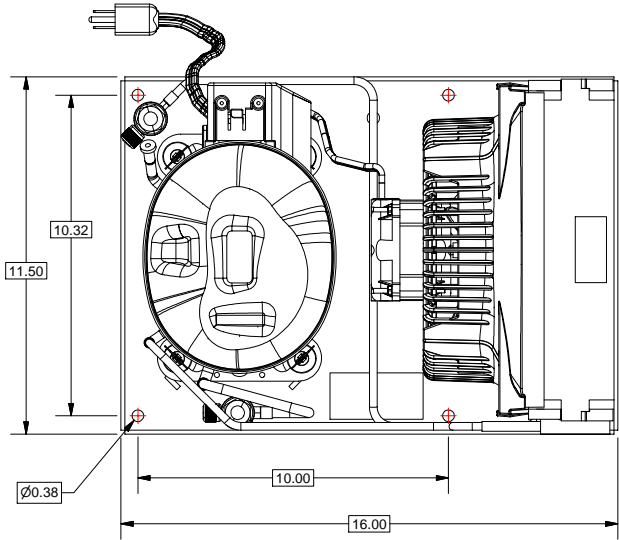

4

3

2

1